

Industrial Wood Products, LLC

Model T-24 Hopper Feed Low RPM/High-Torque Grinder

The Safe and Low Cost way to Turn Your Wood Waste Into Profits

STANDARD SPECIFICATIONS:

- * 5/8" to 1 inch structural steel plate construction.
- * Cutter head width is 26 inches by 10 inches in diameter.
- * 30 Tool Steel cutter inserts, available in various configurations and shapes to match the type of waste to be ground.
- * 10 to 25 HP drive motor selection standard, TEFC with 75 HP rated gearbox drive system.
- * Standard cutter head RPM is 135, and optimized for maximum performance.
- * Hydraulic ram is 24 inches wide with a 24 inch stroke, driven by a hydraulic power unit, 3 HP, 3 GPM, with 15 gallon reservoir, 1000 PSI rating.
- * Standard 8 inch material outlet tube.
- * Up to 1,000 pounds per hour grind rate, depending on screen size and material density.
- * 3/8" to 1-1/4 inch material sizing screen.
- * 240 VAC/480 VAC, 3 phase, wall mounted control panel.
- * Type wood waste accepted: Block wood up to 20 inches.
- * Approximate shipping weight: 4,800 pounds.

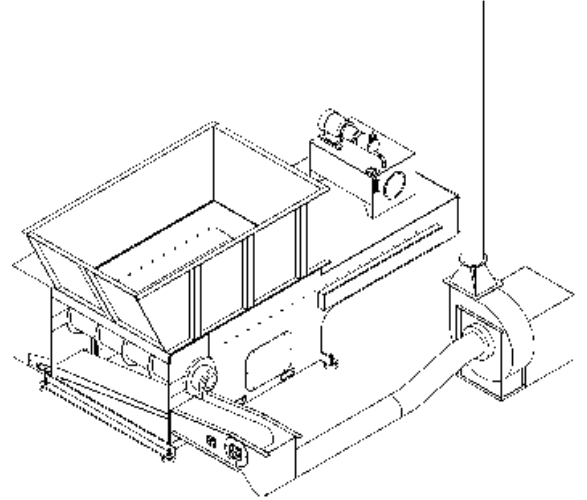

FEATURES:

- * High torque/low RPM gives quiet operation.
- * Bronze guides for smooth ram operation.
- * Heavy duty roller bearings for severe axial and radial loading.
- * Customized cutter head speed.
- * Maximum performance staggered cutter tooth placement.
- * Various cutter insert configurations to match application.
- * Notched and hardened reversible shear plates.
- * Hydraulically actuated ram.
- * Vibration dampening pads.
- * Various standard hopper design.
- * All readily available U.S. electrical and mechanical components.

OPTIONS:

- * Customized ram stroke.
- * Different styles of conveying material infeed systems..
- * Customized hopper.
- * Auger, pneumatic, or conveyor outfeed systems with magnetic separation.



Industrial Wood Products, LLC

P. O. Box 22
Clermont, IA. 52135
web: www.IndustrialBiomass.com

phone: 563-423-1800
fax: 563-423-1801
email: IWP@IndustrialBiomass.com

