

Industrial Wood Products, LLC

Model T-18 Hopper Feed Low RPM/High-Torque Grinder

The Safe and Low Cost way to Turn Your Wood Waste Into Profits

FEATURES:

- * High torque/low RPM gives quiet operation.
- * Bronze guides for smooth ram operation.
- * Heavy duty roller bearings for severe axial and radial loading.
- * Customized cutter head speed.
- * Maximum performance staggered cutter tooth placement.
- * Various cutter insert configurations to match application.
- * Notched and hardened reversible shear plates.
- * Pneumatic actuated ram.
- * Vibration dampening pads.
- * Various standard hopper design.
- * All readily available U.S. electrical and mechanical components.

OPTIONS:

- * Customized ram stroke.
- * Different styles of conveying material infeed systems.
- * Customized hopper.
- * Auger, pneumatic, or conveyor outfeed systems with magnetic separation.

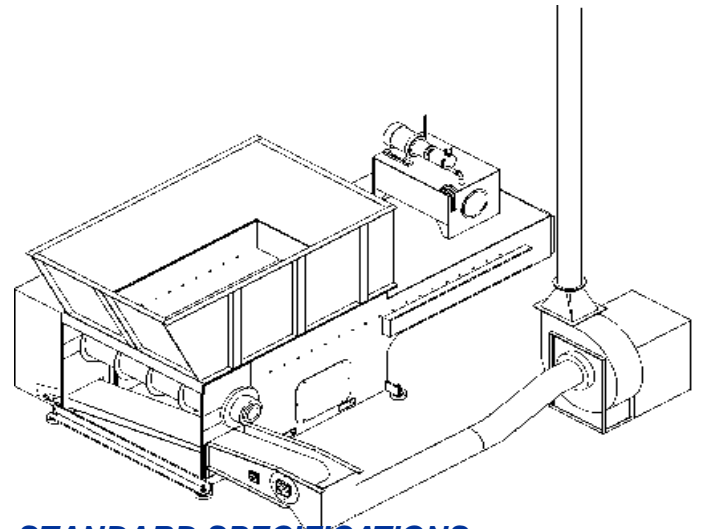

STANDARD SPECIFICATIONS:

- * 5/8" to 1 inch structural steel plate construction.
- * Cutter head width is 20 inches by 6 inches in diameter.
- * 36 Tool Steel cutter inserts, available in various configurations and shapes to match the type of waste to be ground.
- * 7.5 to 15 HP drive motor selection standard, TEFC with belt drive system.
- * Standard RPM is 250, and optimized for maximum performance.
- * Hydraulic ram is 18 inches wide with a 16 inch stroke.
- * Standard 6 inch material outlet tube.
- * Up to 750 pounds per hour grind rate, depending on screen size and material density.
- * 3/8" to 1 inch material sizing screen.
- * 220 VAC, 1 phase; or 240 VAC/480 VAC, 3 phase, wall mounted control panel.
- * Type wood waste accepted: Block wood up to 15 inches.
- * Approximate shipping weight: 3,200 pounds.



Industrial Wood Products, LLC

P. O. Box 22
Clermont, IA. 52135
web: www.IndustrialBiomass.com

phone: 563-423-1800
fax: 563-423-1801
email: IWP@IndustrialBiomass.com

